

CHAPTER 3 (C)

**PHYSICAL DESCRIPTION AND DATA OF MAJOR COMPONENTS
OF THE RADAR COURSE DIRECTING CENTRAL**

**Section I (U). OVERALL PHYSICAL DESCRIPTION OF THE
RADAR COURSE DIRECTING CENTRAL**

27 (U). General

The RCDC described in this manual is emplaced in a fixed Continental United States (CONUS) site. The two basic RCDC site configurations described are the inline configuration and the "T" configuration, each having specific advantages of minimum radar masking or of equipment location and real estate economy. Variations of the two basic configurations are employed as dictated by site characteristics. The area in which the RCDC is emplaced is designated the battery control area and is preferably situated on high ground so that the best possible radar coverage is obtained. The two basic site configurations are described in paragraphs 28 and 29.

Note. The term "primary target line" is defined as the line bisecting the sector in which targets are most likely to be engaged by the battery in the event of an attack. The RCDC is preferably arranged to provide maximum coverage in the direction of the primary target line, although individual site characteristics may make a different orientation of equipment necessary. The term "equipment primary target line" (3, fig. 13) is defined by the actual equipment arrangement in an individual site and is not necessarily the same as the primary target line.

28 (U). Inline Configuration

The inline configuration of the RCDC provides minimum radar masking and for this reason is preferred to the "T" configuration described in paragraph 29. The inline configuration can be either nonconsolidated or consolidated. The two types of inline configurations are described in *a* and *b* below.

Note. The key numbers shown in parentheses in *a* below refer to figure 13.

a. Nonconsolidated Site. The nonconsolidated inline configuration (fig. 13) is employed if it is practical to relocate equipment when a

NIKE-HERCULES System is converted to an Improved NIKE-HERCULES System. The electronic shop building and FUIF room (11), and power building (5) used in the NIKE-HERCULES System are retained when the site is converted to the Improved NIKE-HERCULES System. In systems with HIPAR/AAR the radar antenna support set (2) or the AAR antenna group (13) and the concrete base (14) are located along the equipment primary target line. The trailer mounted tracking station (7) and trailer mounted director station (12) are joined to the electronic shop building. The LOPAR antenna-receiver-transmitter group (8) is located to either side of the equipment primary target line, a minimum of 100 feet from the nearest track or range antenna-receiver-transmitter group, a minimum of 50 feet from both the trailer mounted tracking station and the trailer mounted director station. The radar test set group (1) is located from 600 to 680 feet from the equipment primary target line and is equidistant from the target track antenna-receiver-transmitter group and the missile track antenna-receiver-transmitter group. For a more detailed discussion of the siting requirements, refer to TM 9-1430-251-10/2.

b. Consolidated Site. The consolidated inline configuration is employed in new sites for the Improved NIKE-HERCULES System. The layout is similar to the nonconsolidated inline configuration described in *a* above, except that the electronic shop building (11, fig. 13) is omitted and the trailer mounted tracking station (3, fig. 14) and trailer mounted director station (2, fig. 14) are joined to the HIPAR building (4, fig. 14). A FUIF room (1, fig. 14) is appended to the HIPAR building (4, fig. 14). In a consolidated site, the FUIF room houses the FUIF equipment which, in a nonconsoli-

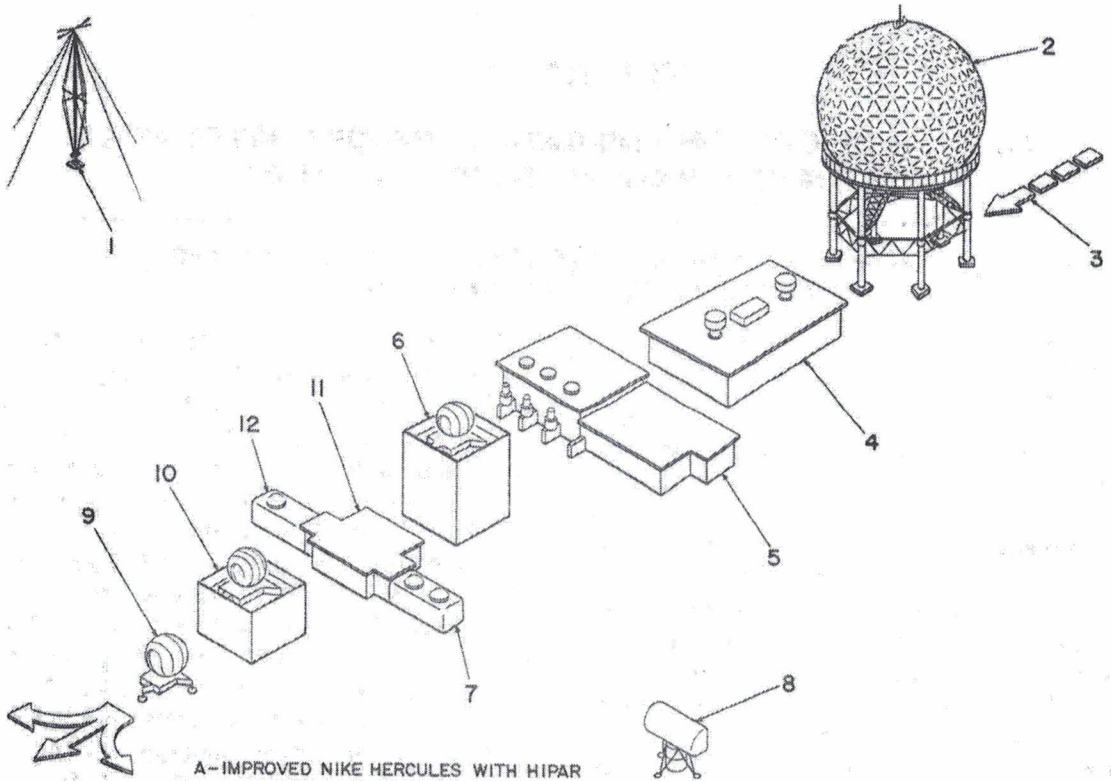

A-IMPROVED NIKE HERCULES WITH HIPAR

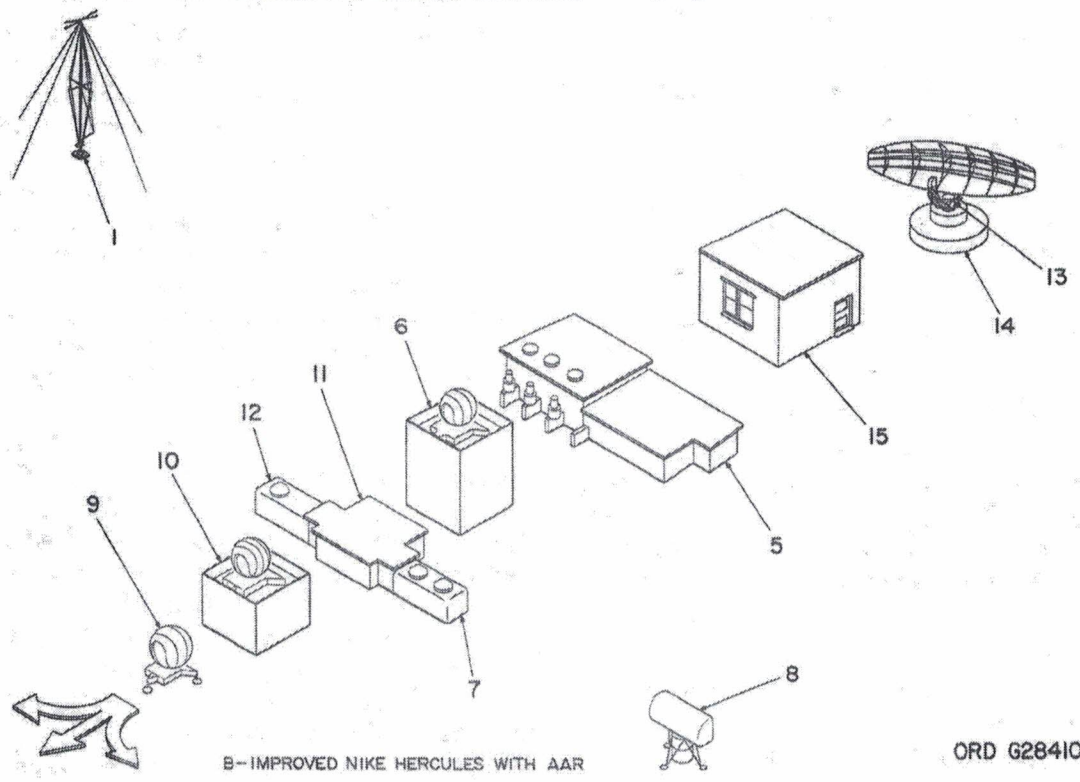

B-IMPROVED NIKE HERCULES WITH AAR

ORD G284107

Figure 13 (U). RCDC—nonconsolidated inline configuration—typical layout (U).

- | | |
|---|--|
| 1—Radar test set group | 9—Missile track antenna-receiver-transmitter group |
| 2—Radar antenna support set and radome | 10—Target range antenna-receiver-transmitter group |
| 3—Equipment primary target line | 11—Electronic shop building and FUIF room |
| 4—HIPAR building | 12—Trailer mounted director station |
| 5—Power building | 13—AAR antenna group |
| 6—Target track antenna-receiver-transmitter group | 14—Concrete base |
| 7—Trailer mounted tracking station | 15—AAR shelter |
| 8—LOPAR antenna-receiver-transmitter group | |

Figure 13 (U). RCDC—nonconsolidated inline configuration—typical layout —legend (U).

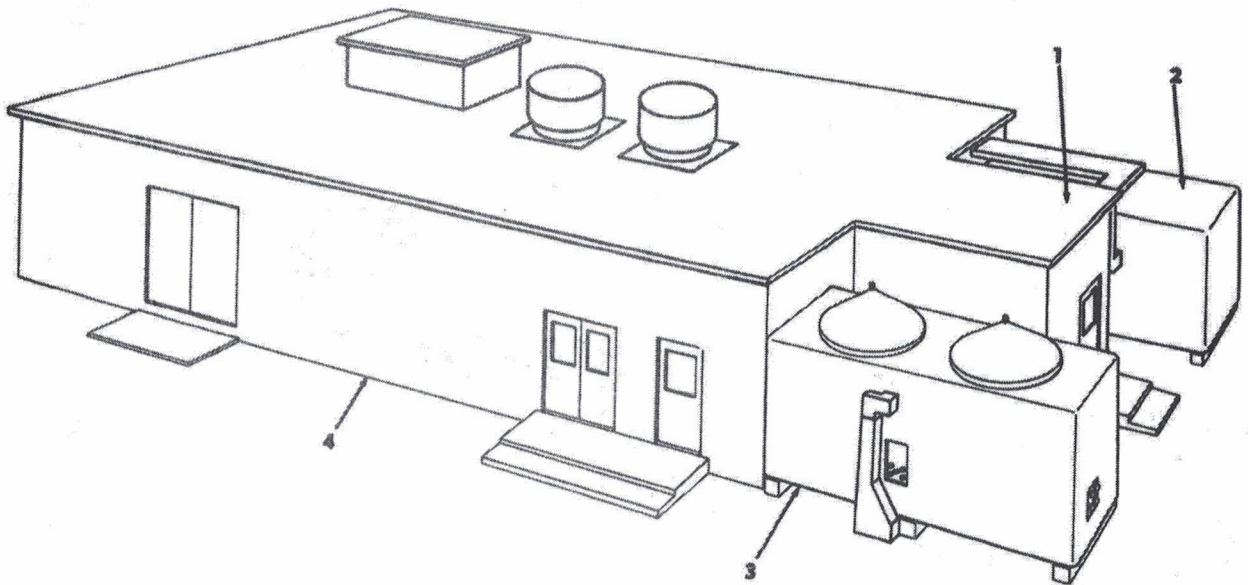

1—FUIF room
2—Trailer mounted director station

3—Trailer mounted tracking station
4—HIPAR building

ORD G56051

Figure 14 (U). HIPAR building—consolidated site (U).

dated site, is housed in the electronic shop building.

29 (U). "T" Configuration

a. The "T" configuration (fig. 15) of the RCDC makes economical use of real estate and provides convenient arrangement of equipment. The "T" configuration is nonconsolidated and is employed at sites converted from the NIKE-HERCULES System to the Improved NIKE-HERCULES System when lack of available real estate, unfavorable terrain characteristics, or the cost of relocating emplaced equipment prohibits conversion to an inline configuration.

Note. The key numbers shown in parentheses in b below refer to figure 15.

b. In the "T" configuration, the radar antenna support set and radome (3), or the AAR antenna (13) and concrete base (14), HIPAR building (4), or the AAR shelter (15), and electronic shop building and FUIF room (6) are arranged on the equipment primary target line (2). The target track and missile track

antenna-receiver-transmitter groups (9 and 11) are located forward of the other RCDC equipment and on a line perpendicular to the equipment primary target line. The target range antenna-receiver-transmitter group (8) is located near the target track antenna-receiver-transmitter group. The radar test set group (1) is emplaced behind the radar antenna support set and radome within 80 feet of the equipment primary target line. The trailer mounted tracking station (5) and trailer mounted director station (7) are joined to the electronic shop building. The power building (12) is near the electronic shop building. The LOPAR antenna-receiver-transmitter group (10) is located a minimum of 100 feet from the nearest target track or target range antenna-receiver-transmitter group and a minimum of 50 feet from both the trailer mounted director station and the trailer mounted tracking station. For a more detailed discussion of the siting requirements, refer to TM 9-1430-251-10/2.

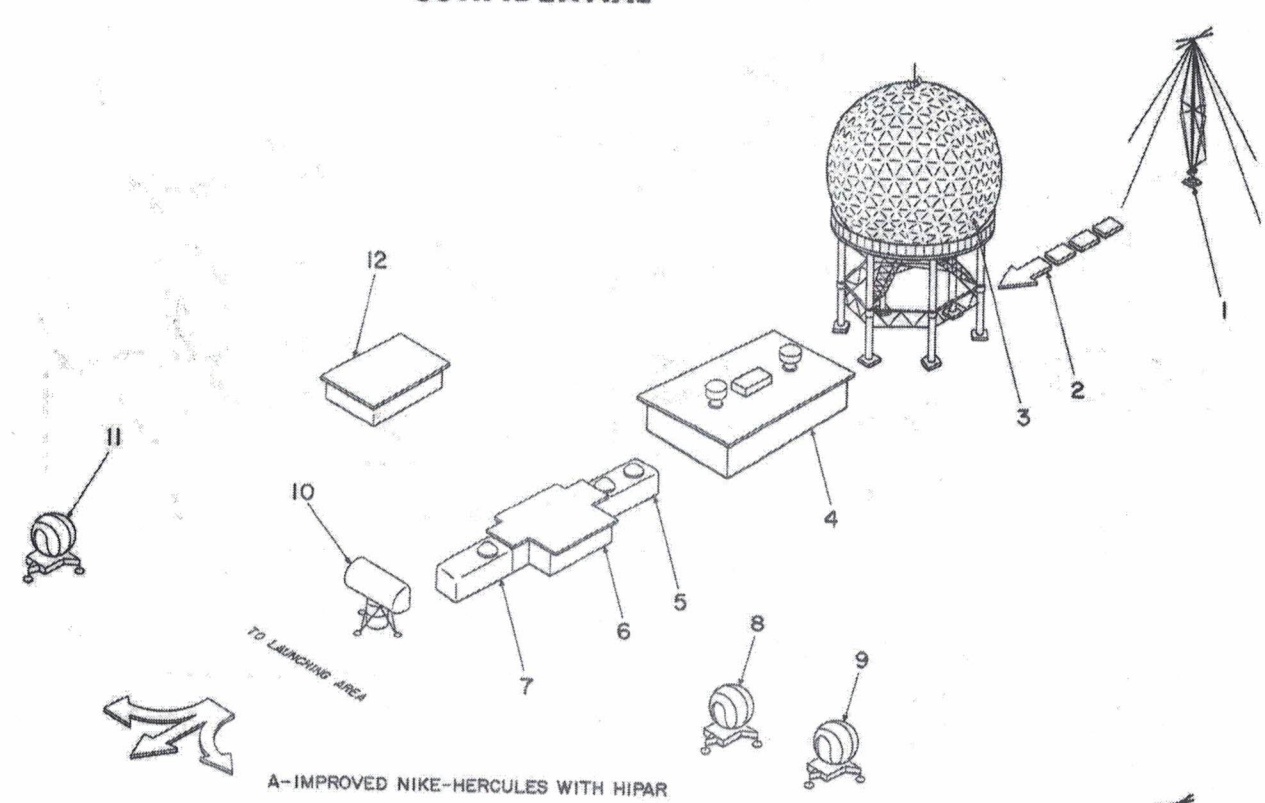

A-IMPROVED NIKE-HERCULES WITH HIPAR

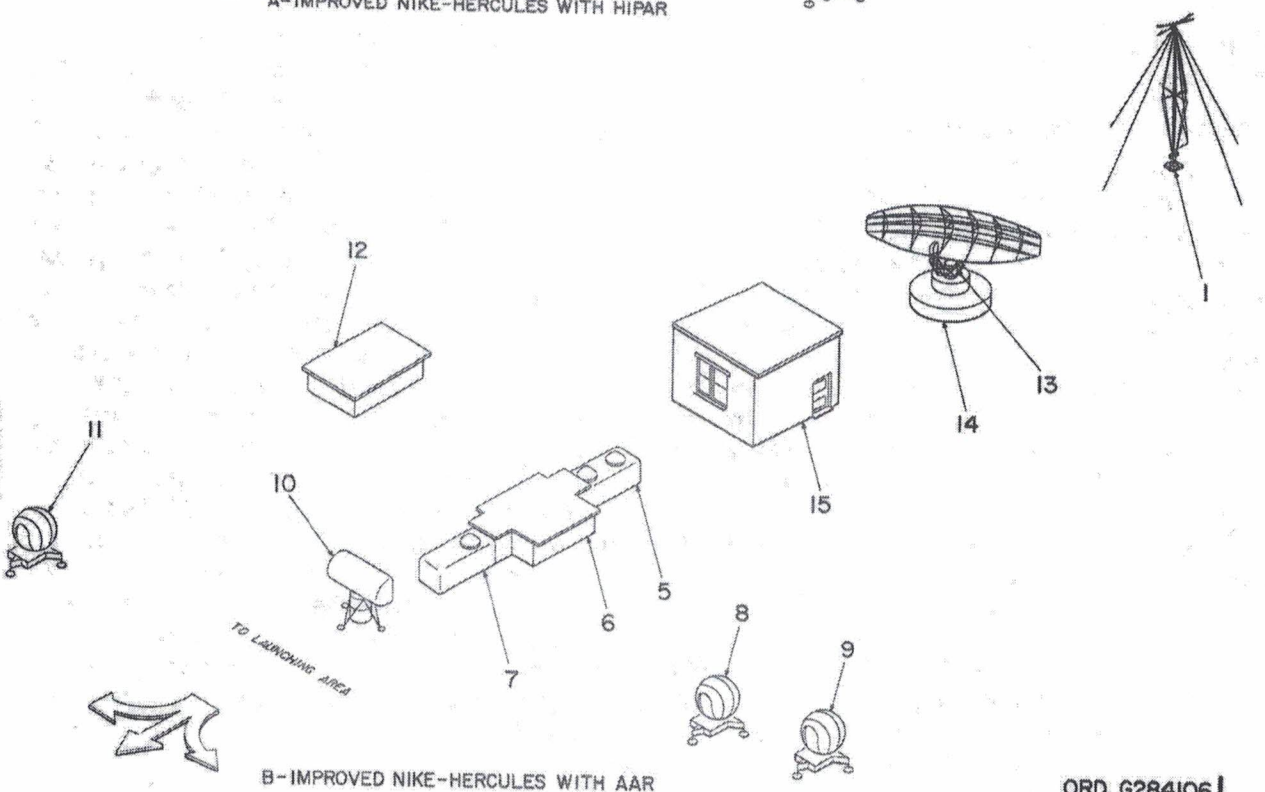

B-IMPROVED NIKE-HERCULES WITH AAR

ORD G284106

Figure 15 (U). RCDC—nonconsolidated "T" configuration—typical layout (U).

- | | |
|---|---|
| 1—Radar test set group | 9—Target track antenna-receiver-transmitter group |
| 2—Equipment primary target line | 10—LOPAR antenna-receiver-transmitter group |
| 3—Radar antenna support set and radome | 11—Missile track antenna-receiver-transmitter group |
| 4—HIPAR building | 12—Power building |
| 5—Trailer mounted tracking station | 13—AAR antenna group |
| 6—Electronic shop building and FUIF room | 14—Concrete base |
| 7—Trailer mounted director station | 15—AAR shelter |
| 8—Target range antenna-receiver-transmitter group | |

Figure 15 (U). RCDC—nonconsolidated "T" configuration—typical layout—legend (U).

Section II (U). PHYSICAL DESCRIPTION OF THE TRAILER MOUNTED DIRECTOR STATION

30 (U). General

a. In a fixed CONUS site, the trailer mounted director station is joined either to the electronic shop building, as shown in figure 13, or to the HIPAR building, as shown in figure 14. In either configuration, the entrance door at the rear of the trailer is removed and access to the trailer is through the adjoining building. The undercarriage of the trailer is also removed and the trailer is supported on blocks or beams.

Note. The key numbers shown in parentheses in *b* below refer to figure 16.

b. Major components of the trailer mounted director station are the computer group (3),

early warning plotting board (5), auxiliary acquisition control interconnecting group (6), battery control console (14), recorder group (16), personnel heater (17), director station group (18), utility cabinet (19), and equipment cooling cabinet (20). These components are described in paragraphs 31 through 38. Trailer lighting equipment is described in paragraph 39 and miscellaneous equipment is described in paragraph 40.

31 (U). Computer Group

The computer group (3, fig. 16) consists of the computer amplifier-relay group (3A, fig. 16), servo computer assembly (3B, fig. 16), and