

The Meccano Set Computers

A history of differential analyzers made from children's toys

By Tim Robinson

History of Analog Computing

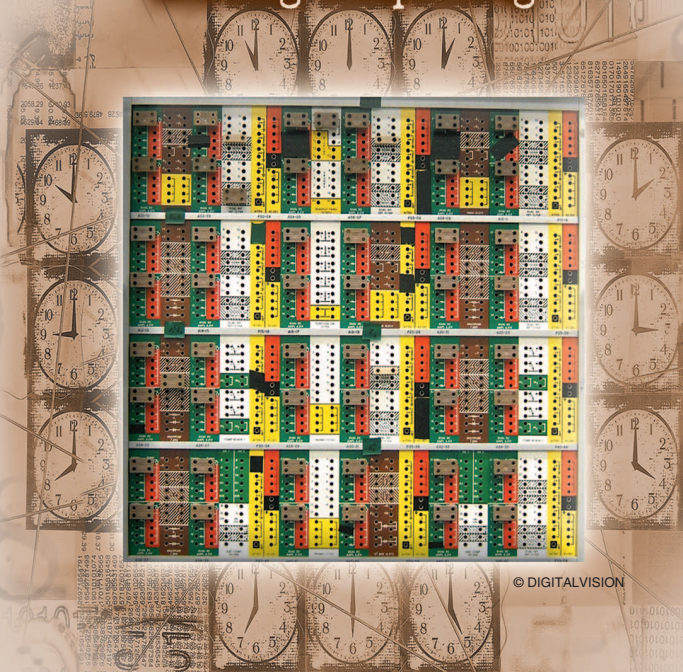

During the 1930s and 1940s, a surprising number of mechanical analog computing machines were constructed, mostly in the United Kingdom, using little more than a large Meccano set. These machines, known as small-scale differential analyzers, were used for both scientific research and, with the outbreak of war in Europe, for military ballistics work. Simpler models were built in colleges and high schools for use as calculus teaching aids.

The Differential Analyzer

The first differential analyzer, built in 1931 by Vannevar Bush at MIT [1], grew out of a number of earlier and more specialized machines constructed to help solve differential equations related to transients on long-distance power transmission lines, such as those caused by lightning strikes. Bush's machine consisted of six mechanical wheel-and-disk integrators, XY plotting tables for providing input and recording output, and a complex system of interconnecting shafts to enable the various units to be interconnected according to the requirements of a particular problem (Figure 1).

The principle of a mechanical integrator is illustrated in Figure 2. Suppose we wish to integrate a function $f(x)$ with respect to the independent variable x . A small wheel rolls on the surface of a horizontal disk. The displacement of the wheel from the center of the disk varies continuously. The displacement, controlled by a lead screw, is proportional to the value of the function $f(x)$ to be integrated. A small rotation of the horizontal disk represents a change δx in the value of the independent variable x . The rotation of the wheel then records the value of

$$A \int f(x) dx,$$

where A is a constant scaling factor that depends on the physical size of the components. With such a device, integration can be performed with respect to an arbitrary variable rather than just time, giving the mechanical differential analyzer great power. However, since the wheel must be able to slide freely in the radial direction on the disk, only light pressure can be applied. This constraint severely limits the available torque that can be derived from the output.

The concept of the differential analyzer (though he did not use that name) was first published by William Thomson, later Lord Kelvin, in 1876 [2]. Kelvin was unable to reduce the concept to practice due to the difficulty of driving a second integrator using only the feeble output of the first. Ignoring this practical problem, he describes in principle a successive approximation method to obtain increasingly accurate solutions to a second-order equation on repeated passes through a coupled pair of integrators. He then goes on:

But then came a pleasing surprise. Compel agreement between the function fed into the double machine and that given out by it. . . . The motion of each will thus be necessarily a solution of [the equation]. Thus I was led to the conclusion, which was unexpected; and it seems to me very remarkable that the general differential equation of the second order with variable coefficients may be rigorously, continuously, and in a single process solved by a machine. [2]

As an example, to solve the second-order equation for simple harmonic motion given by

$$\frac{d^2 y}{dt^2} = -\omega^2 y,$$

two integrators would be interconnected with the output of each connected to the input of the other and with the disks turned together by a common shaft representing the independent variable t . A schematic diagram illustrating this connection, using a notation introduced by Bush [1], is shown in Figure 3.

Kelvin was mainly interested in the problem of harmonic analysis, extracting Fourier coefficients from decades of recorded tidal data to predict the heights of future tides. He built a successful harmonic analyzer using a large number of integrators based on a design by his brother, James Thomson. In this machine, each integrator, which computes only a single Fourier coefficient, is not required to drive further machinery. Human operators feed in the historic tidal data by turning a crank to follow a plotted curve and then record the result computed by the integrators. It is curious, therefore, that Kelvin did not hit on the idea of using human “servos” to track the output of the integrators

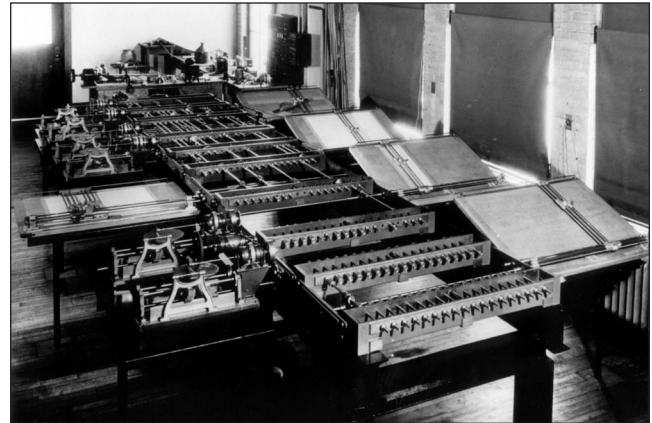

Figure 1. Vannevar Bush's prototype differential analyzer at MIT in 1931. On the left are the six integrators in pairs, with the output table between them. On the right are four input tables. Down the center runs the system of shafts, which could be reconfigured to interconnect the units for a specific problem. (Courtesy of the MIT Museum.)

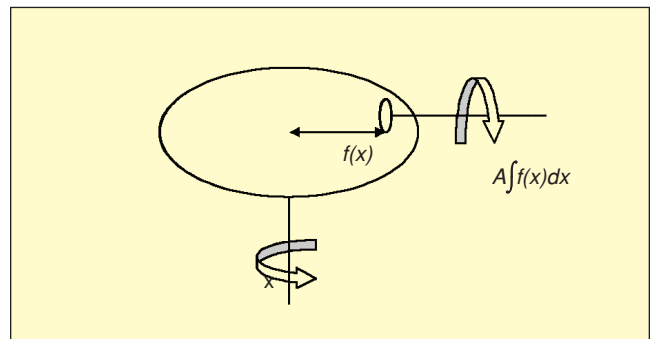

Figure 2. Wheel and disk integrator. The displacement of the wheel from the center of the disk, which is continuously variable, represents the function $f(x)$. The position of the shaft carrying the disk represents the value of the variable x . The motion of the shaft carrying the wheel is then proportional to the required integral.

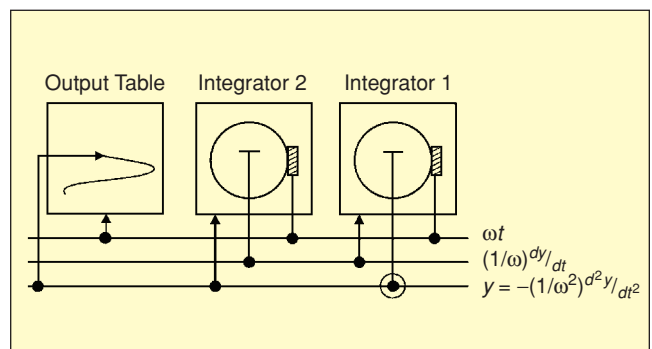

Figure 3. Schematic setup for simple harmonic motion. The notation used is that of Bush [1] and is largely self explanatory. Bus shafts are labeled according to the quantities they represent.

Meccano

Readers, particularly in the United States, may not be familiar with Meccano, a child's educational construction system similar to Erector. Meccano was invented in 1901 in England by Frank Hornby. In England, and indeed throughout most of the former British Commonwealth in the first half of the 20th century, Meccano was ubiquitous, and almost every young boy had a Meccano set. For a toy, Meccano includes a surprisingly sophisticated set of gears and other mechanical components, manufactured to precision adequate to allow the construction of complex mechanisms.

and act as power amplifiers, which would have allowed them to be cascaded.

According to his autobiography *Pieces of the Action* [3], Bush was unaware of Kelvin's work until after the first differential analyzer was operational. The crucial components of Bush's machine are mechanical torque amplifiers, which had been invented a few years earlier by Nieman [4]. These components are used to amplify the output of each integrator so as to drive the load presented by the rest of the machine. In this manner, Bush was able to surmount the barrier that had prevented Kelvin from building a practical machine 50 years earlier. As shown in Figure 4, these torque amplifiers operate on a capstan principle with a pair of belts wrapped around contra-rotating drums. Any motion of the input shaft

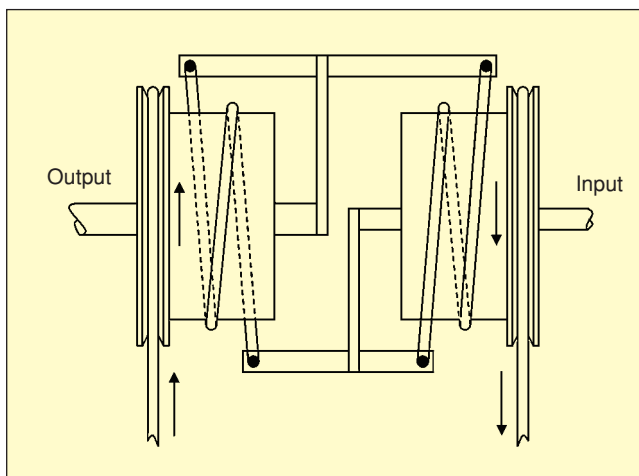

Figure 4. Principle of the torque amplifier. Two drums are continuously rotated in opposite directions by an electric motor. When the input shaft turns, one of the bands is tightened around its drum, while the other is slackened, causing the output shaft to be turned in the same direction as the input but with much greater torque.

results in one of the bands tightening around its corresponding drum while the other is loosened. The input torque is multiplied by a factor $e^{\mu\Theta}$, where μ is the coefficient of friction between the band and the drum and Θ is the angle of wrap around the drum. Two stages of amplification in series can achieve a gain of order 10,000 [1].

The other major components of a differential analyzer are adding units, input tables, and one or more output tables. The adding units consist of a differential gear arrangement similar to that in an automobile drive train, which can form the continuous sum or difference of the rotations of two input shafts. The input tables allow plotted functions to be fed into the machine by an operator who turns a crank to move a crosshair in the y direction. The operator keeps the crosshair positioned over the plotted curve while the machine drives the crosshair in the x direction. Thus, as the machine computes a variable x , the operator feeds in an arbitrary function $y = f(x)$. Output tables are similar, except that the crosshair is replaced by a recording pen, which the machine then drives in both directions.

Developments in Manchester

Prof. Douglas Hartree of the University of Manchester was typical in having played with Meccano as a child (see "Meccano"). Hartree was a physicist who is today most widely remembered for his "self-consistent field" method for determining quantum mechanical wave functions for multi-electron atoms. This work was further developed by V. Fock and is now generally referred to as the Hartree-Fock method. This method is iterative; it involves the repeated numerical solution of differential equations that, in the days of hand-cranked desk calculators, could entail months of work to obtain a single set of consistent solutions.

Hartree soon heard of Bush's work on mechanizing the solution to differential equations, and his first impression on seeing pictures of the differential analyzer was that "they looked as if someone had been enjoying themselves with an extra large Meccano set" [5]. In 1932, Hartree visited MIT to learn more about the analyzer and to attempt to use the analyzer for an atomic physics calculation, for which it proved eminently suitable. On returning to Manchester, Hartree was determined to build a model, mostly from Meccano, to qualitatively demonstrate the basic principles of the machine. His objective was to rally support for the construction of a full-scale machine at the University. To this end, he sought out a research student, Arthur Porter, who first set about the problem of constructing a torque amplifier. Since it was not deemed possible to build a sufficiently powerful and reliable amplifier from the lightweight Meccano parts, this component was created from scratch in the laboratory machine shop. Porter then proceeded to build the rest of the machine (consisting of a single integrator, an input table, and an output table) entirely from Meccano, as a "proof of concept" model.

The single-integrator model, which was set up to solve the first-order equation

$$\frac{dx}{dt} = -at,$$

performed so well that Hartree immediately gave the go-ahead to build two more integrators. Besides the torque amplifiers, the only other custom components required were right-angle helical gears for the more complex interconnect between the units once the extra integrators were added. In 1934, such gears were not included in Meccano's standard parts range; the company added them late the following year, perhaps as a result of seeing their vital role in the differential analyzer models. Hartree can be seen in Figure 5 watching over the operation of the completed model machine, while Porter operates the input table.

The three-integrator machine was successful beyond expectation, delivering an accuracy of 1–2%. One of the first problems Porter tackled was a calculation of the radial wave functions of the chromium atom.

Figure 6 shows schematically the setup of the machine for this problem. The horizontal lines represent the bus shafts of the machine. The shaft representing the independent variable ρ was to be driven by a motor, from which the motion of all other shafts would follow. The input table contains a previously computed plot of the function

$$2Z\rho r - \epsilon r^2 - \left(l + \frac{1}{2}\right)^2 \text{ versus } \log r$$

to be fed in by an operator. Even though the equation is only of the second order, this setup makes use of three integrators. To understand this, note that the integral of a product of two functions can be evaluated using the identity

$$\int f(x)g(x)dx = \int f(x)d\left(\int g(x)dx\right),$$

which requires two integrators but avoids the need for a multiplier. In general, for nontrivial equations, more integrators are required than the mathematical order of the

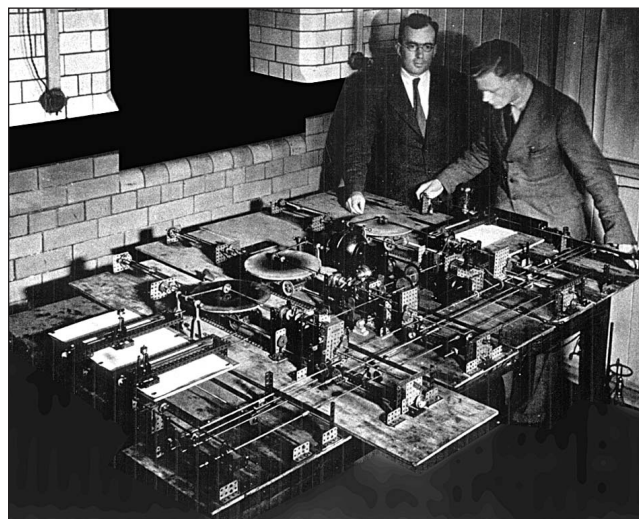

Figure 5. Hartree and Porter with the Meccano model. The three integrators are in the center of the machine. The motor powering the torque amplifiers can be seen between them. On the left is the dual-output table, and on the right is an input table being operated by Porter. (Courtesy of R. Hartree.)

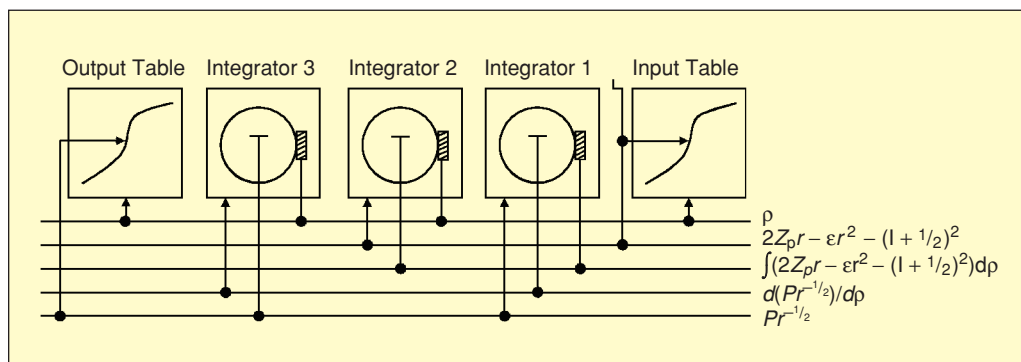

Figure 6. Schematic setup for the chromium atom wavefunction. The equation being solved by this setup is $d/d\rho(Pr^{-1/2}) = -\int(2Z\rho r - \epsilon r^2 - (l + 1/2)^2)Pr^{-1/2}d\rho$, where $\rho = \log r$. The output table records the value of $Pr^{-1/2}$ as a function of $\log r$.

equation. For example, the multiplication of an arbitrary pair of functions can be performed by two integrators and an adder by using the identity

$$f(x)g(x) = \int f(x)d(g(x)) + \int g(x)d(f(x)).$$

Likewise, auxiliary functions can often be generated on the fly, rather than requiring an operator to feed them in from an input table, by using additional integrators. This option holds so long as the required function can be expressed as the solution to an auxiliary differential equation. This method takes full advantage of a mechanical integrator's ability to integrate with respect to an arbitrary variable.

Figure 7 shows a sample of the actual output drawn by the model for this problem. The construction of the machine, together with its use to determine the atomic wave functions of the chromium atom, formed the basis of Porter's M.Sc. thesis. The work was later published in a pair of papers [6], [7].

With the success of the model, Hartree was able to secure financial support to build a full-scale, fully engineered machine. Design and construction were contracted to the Metropolitan Vickers Company. A four-integrator analyzer was commissioned in a ceremony at the university in March 1935. Additional funds were soon found to increase the number of integrators to eight, making this machine more powerful than Bush's prototype.

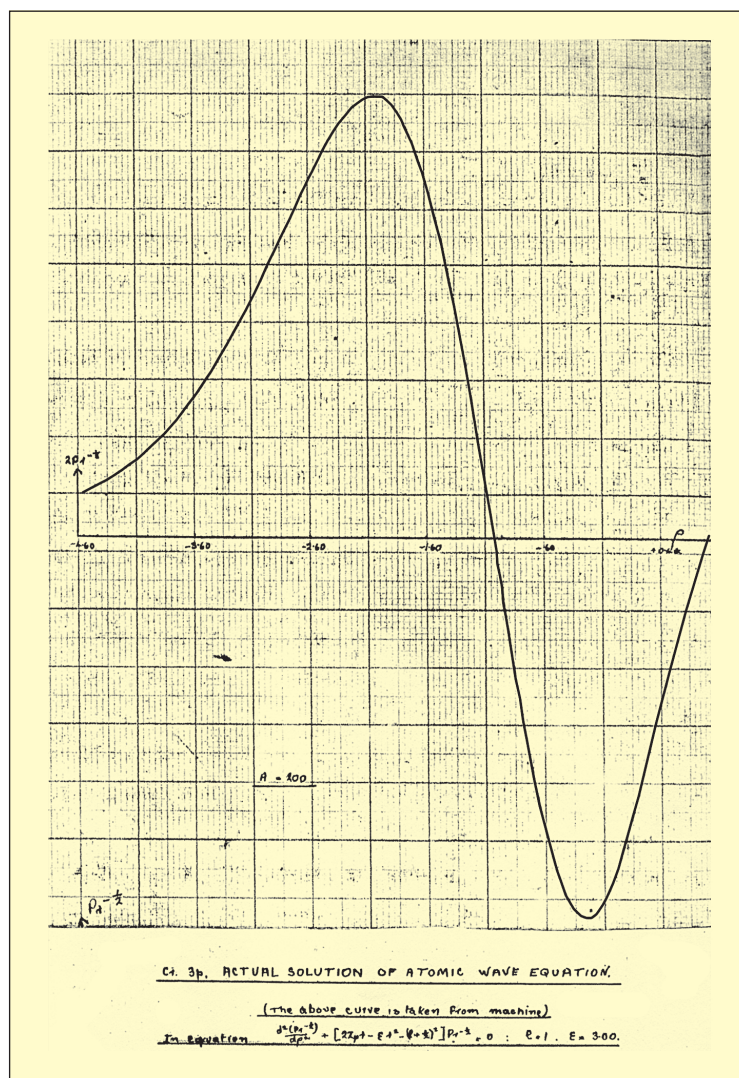

Figure 7. Actual output from the Meccano model. This plot is taken from the M.S. thesis of A. Porter, which, along with a single integrator from his model, now forms part of a permanent display at the Science Museum in London. (Courtesy of A. Porter.)

The Meccano Company published the popular monthly *Meccano Magazine*, which in the 1930s had a circulation of about 80,000 worldwide. The company lost no time in capitalizing on the use of Meccano as an aid to scientific research. In the June 1934 issue, there appeared two articles, the first describing Bush's machine and the second detailing the Hartree and Porter Meccano model. This wide exposure quickly led to the construction of many small model machines in colleges and high schools, where they provided excellent calculus teaching aids.

One of the areas that gained Hartree's interest was the newly emerging theory of control systems [8]. In many such problems, complex aspects of the system could be approximated by a fixed time lag in the system, where the solution to the problem at time t depends explicitly on the solution at some earlier time $t - \tau$. As an experiment, Porter modified the input table of the Meccano model so that it could simultaneously record the result of the computation and allow this result to be continuously fed back into the machine at a later time. By adjusting the separation of the recording pen and the input cross-hairs to represent the fixed time delay τ , a computed result $f(t)$ recorded by the pen at time t would pass under the cross-hairs at the later time $t + \tau$, when it would be fed back into the machine. The technique was successful, and Hartree immediately had similar changes made to the full-scale analyzer.

At about the same time, to further increase the scope of the Meccano model, a fourth integrator was added. The new integrator differed from the first three in that it had an improved two-stage torque amplifier. This integrator has been preserved and is now on permanent display at the Science Museum in London. The display includes Porter's M.Sc. thesis, open to a page that shows the beautiful plot obtained on the model for the chromium atom wave function. Also preserved at the Science Museum is a four-integrator section of the Metropolitan Vickers full-scale analyzer.

The Cambridge Model

Hartree had strong connections to Cambridge University, where J.E. Lennard-Jones was professor of theoretical chemistry. It is thus not surprising that a copy of his Meccano model was quickly built in Cambridge (Figure 8). Lennard-Jones instigated the construction of a four-integrator model, built in 1935 by J.B. Bratt [9]. Hartree and Porter offered much valuable experience, and the Cambridge machine incorporated many new features to enhance the accuracy. Improvements included lashlocks on the integrator lead screws, larger integrator disks carried on ball bearings, hardened

steel integrator wheels, and two-stage torque amplifiers, as subsequently used on the fourth integrator added in Manchester. The Meccano Company assisted in this development by providing some specially made parts, such as longer lead screws and axles. The measured accuracy of the integrators on this machine was 0.15%, which compared favorably to the 0.1% accuracy obtained on Bush's full-scale prototype.

The Cambridge model has a long and interesting history. In 1936, Maurice Wilkes attended a lecture on the differential analyzer delivered in Cambridge by Hartree. The lecture was accompanied by a demonstration of the new Meccano model. In his autobiography [10], Wilkes recalls: "It was a model in the sense that it was made from Meccano parts, Meccano being a popular toy that I and practically every other boy in the country had been brought up on." He adds: "As a piece of mechanism I found the machine irresistible." He lost no time in seeking access to the model for use in his work on ionospheric radio propagation, the results of which were later published in the *Proceedings of the Physical Society*. When Bratt left Cambridge at the end of 1936, Wilkes took over day-to-day operation and management of the machine. In 1937, Elizabeth Monroe, a research student who was assisting in the solution of a problem in nuclear physics that stretched the capabilities of the model, constructed and successfully added a fifth integrator. With the extra capacity of the additional integrator, she was able to obtain the required solutions.

Just as in Manchester, the success of the model machine led to the installation of another full-scale analyzer as part of the newly established Computing Laboratory, a facility that would be available to all of the University rather than just the Theoretical Chemistry Group. The machine was delivered in 1939, just as war broke out in Europe, and it was immediately taken over by the government for war work. The model machine underwent a number of enhancements to improve the reliability and ease of setup. It too was used for military applications, including thermal conduction and convection problems, investigation of the detonation wave of high explosives, and electrical transmission-line studies [11].

After the war, under the direction of Wilkes, the Cambridge Computer Laboratory quickly became focused on developments in digital computing, building the EDSAC (Electronic Delay Storage Automatic Calculator). The differential analyzers fell into disuse. In 1948, Dr. H. Whale, who had earlier used the Meccano model in his Ph.D. studies, purchased it for the sum of UK£100. He transported it to New Zealand, where he used it at the Seagrove Radio Research Station, University of Auckland. It is believed to be the first computer used in that country [12].

After a number of years at the Radio Research Station, the model moved to the Department of Scientific and Industrial Research, where it was used for several projects



Figure 8. The Cambridge Model. J. Corner (seated) is operating the input table. Standing are A.F. Devonshire (left) and M.V. Wilkes (right). (Courtesy of M.V. Wilkes.)

including geothermal studies and the modeling of a hydroelectric system. By the early 1960s, the inevitable march of digital technology meant the machine had outlived its usefulness as a scientific research tool, and the machine was given to the Wellington Polytechnic. For a time, the machine was maintained at Wellington for teaching purposes, but then finally was dismantled and stored. In 1973, Dr. H. Offenburger of the Polytechnic rediscovered the machine in storage and arranged for it to be donated to the Museum of Transport and Technology (MOTAT) in Auckland. There, it was reunited with Whale, who employed two students to restore it to operation for display. The event was reported in the *New Zealand Herald* newspaper in a brief article titled "Toy Used to Build 'Brain Box' in 1930s." This report was seen by the New Zealand agent of the Meccano Company, who reported it to the editor of *Meccano Magazine*; an article duly appeared there in the October 1973 edition.

The machine was maintained in working condition for demonstrations (Figure 9). Indeed, the museum has an operation and maintenance manual written as recently as 1978 [13]. However, in the late 1980s, the museum ran into financial trouble, and many items on loan for exhibit were removed by their owners. These circumstances forced the closure of the computing exhibit, and the Meccano analyzer was broken down once more and stored. In 1993, Garry Tee of the Mathematics Department at the University of Auckland heard that there were no longer any computer-related items on display at the museum. Upon inquiring into the fate of the model, he learned the Meccano analyzer had been dismantled, stored, and then, after suffering water damage, scrapped [12]. Tee was outraged that such a historically significant artifact should have been treated this way. Articles reporting on the loss appeared in the *New Zealand Herald* on 20 April 1993 and again a week later. These reports led to an

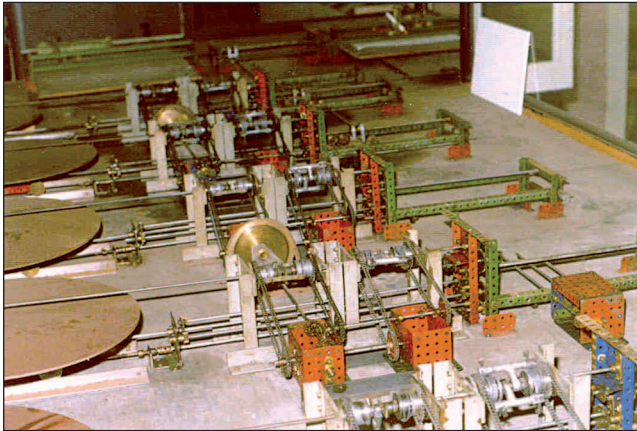

Figure 9. The Cambridge model on display at MOTAT in 1978. Integrator disks can be seen on the left. The torque amplifiers, powered through chain drives, are down the center. Just visible at the rear are the input and output tables. (Courtesy of A. Barton.)

article in *New Scientist* the following month titled “Ancient Computer Down and Out” [14].

The negative publicity prompted the staff at MOTAT to investigate further, and they discovered that only a small piece of the model had been scrapped after suffering water damage in storage. The remainder had simply been misplaced due to an error in the storage paperwork. It was quickly found again but in fairly poor condition. The *New Zealand Herald* reported on the rediscovery, printing an interview with the very relieved museum director, who indicated that every effort would be made to restore it. After a decade in limbo, a project to restore the machine for permanent display is now finally underway, led by two local Meccano enthusiasts, William Irwin and John Denton.

Other Wartime Models

During the war, the full-scale machines in Manchester and Cambridge were turned over for war-related work. Hartree provided oversight for many such projects for the Ministry of Supply using the Manchester machine, while the Cambridge machine was used by the Armaments Research Department. A number of the groups Hartree worked with went on to construct or acquire model differential analyzers to continue the work at their own facilities [15]. Although few details of these machines were ever recorded, two that warrant mention are those of R.W. Sloane of the Research Laboratories of the General Electric Co. Ltd. (later acquired by the Air Defence Research and Development Establishment) and J. Benson of the Coast Artillery Experimental Establishment. Both of these machines had substantial Meccano content, and both were used for wartime work in the field of fire control systems.

Construction of another Meccano model began in 1942 at the Physics Department of the University of Birmingham by an M.S. student, A.M. Wood [16], working with Prof.

Rudolph Peierls. The design was ambitious, calling for six integrators. However, wartime shortages made Meccano parts hard to obtain since the U.K. government had banned the sale of metal toys and the Meccano factory had been converted to a die casting facility for government war-related work. Wood managed to complete only two of the planned six integrators and then carried out the remainder of his thesis work using the existing model machine at Cambridge.

The success of the Meccano models stimulated the construction of two small-scale machines following the general layout of the models, but of more substantial and customized construction. One was built by the physicist H.S.W. Massey at the Physics Department of Queen’s University, Belfast [17]. This machine had only four integrators. All of the spur gears were Meccano, but otherwise the machine was constructed from parts custom-manufactured in the laboratory workshops. The entire machine was assembled for UK£50 in materials. In 1938, Massey moved to University College, London, and brought the machine there with him. It was subsequently destroyed in an air raid during the war. The second machine, with six integrators, was built by R.E. Beard [18] and used experimentally for actuarial work. Limited accuracy ultimately ruled out the use of the differential analyzer for serious work in this field, and it was acquired in the early 1940s by the Valve Research Department of Standard Telephones and Cables, Ltd. [15]. Interestingly, despite the more substantial construction of these machines, neither of them achieved better than 1–2% accuracy, quite inferior to the Cambridge Meccano model.

Education

The differential analyzer, by providing a directly observable mechanical analog of a physical system, has great value as a pedagogical tool in teaching fundamental calculus. Vannevar Bush himself noted this fact [3]. He tells the story of a mechanic, initially hired as a draftsman with only a high school education, who worked on construction and maintenance of the differential analyzer. Bush says, “I never consciously taught this man any part of the subject of differential equations; but in building that machine, managing it, he learned what differential equations were himself. He got to the point where when some professor got stuck . . . he could discuss the problem with the user and very often find out what was wrong.” He goes on, “He had learned the calculus in mechanical terms—a strange approach, and yet he understood it. That is, he did not understand it in any formal sense, but he understood the fundamentals; he had it under his skin.”

Hartree published several prominent papers on the construction and use of the differential analyzer, including the Meccano model machine, and lectured widely on the subject. The Meccano Company had been quick to capitalize

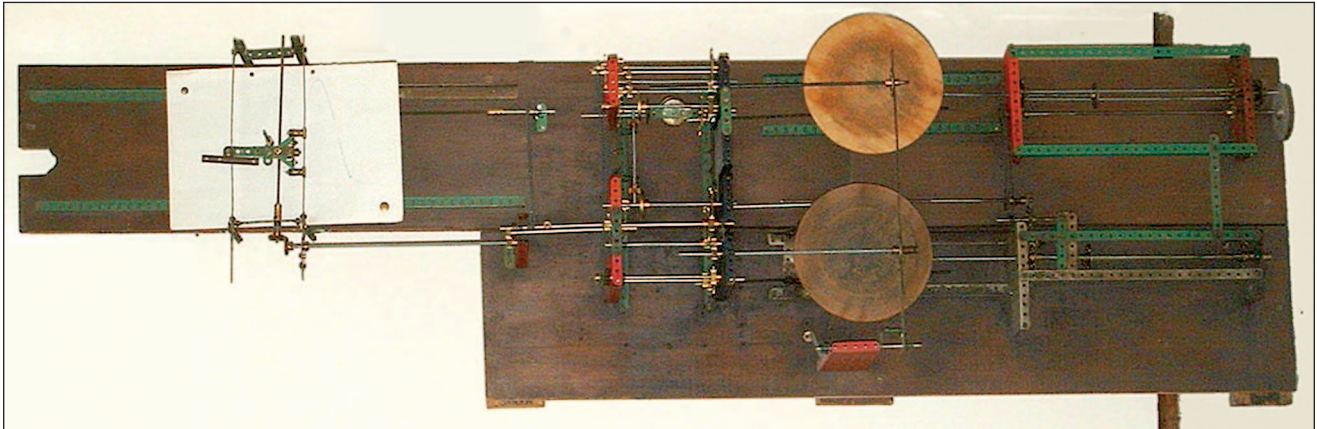

Figure 10. Demonstration model of N. Eyres. This model was recently rediscovered with plotted output still attached to the output table. It is now being restored by Mr Eyres' son-in-law, who kindly provided the photograph. (Courtesy of D. Fargus.)

on the success of his model with articles in the *Meccano Magazine*. Not surprisingly, several small-scale models were built by students and teachers in schools and colleges. These models were never intended to produce results of the accuracy required for serious scientific research, but rather served as educational tools, directly connecting Meccano (at that time almost every boy's hobby) to the more abstract world of mathematics.

Beatrice "Trixie" Worsley, from Canada, completed a Master's thesis at MIT in 1947, which consisted of a comprehensive survey of computing technology at the time. Her thesis includes an appendix with a detailed theoretical and practical analysis of sources of error in the differential analyzer. After completing her thesis, Worsley returned to Toronto, and during the summer of 1948, she constructed a three-integrator Meccano differential analyzer largely modeled on Hartree and Porter's original paper. Worsley's machine cost about CAN\$75 in parts. Documentation survives on this model, in the form of a memo she wrote in September 1948 [19] describing some aspects of the construction. It is not known what purpose she originally intended for this machine. Three integrators would hardly have been enough to tackle interesting research problems, although there are some tantalizing hand-written notes at the end of the archive copy of the memo that suggest she had plans to add two further integrators. Shortly after completing the model, Worsley moved to Cambridge, England, for a time to work with the EDSAC digital computer under development there, leaving the model differential analyzer in Toronto. There also survive notes for a fourth-year physics laboratory experiment at Toronto [20], which describe operation of the machine and led students through the solution of simple problems using it. The existence of these notes mean it is quite likely the model was originally conceived as a teaching aid rather than a research tool.

Around 1951, the machine was resurrected and extended with more integrators by J. Howland, a student of C.C.

Gotlieb. Details of this work are vague, and although a picture of Prof. Gotlieb with the machine appeared in a 1951 edition of the *Toronto Globe and Mail*, only a small corner of the machine is visible. Gotlieb remembers [21] the final machine having five integrators, but it was still used only for teaching purposes and was dismantled shortly afterward since the space was required for something else.

By 1948, Arthur Porter had moved to the Royal Military College of Science in the United Kingdom, where he designed a new and improved four-integrator Meccano differential analyzer [22]. This model was used for educational purposes. A picture in Porter's possession is the only known documentation of this model. The college later went on to construct a full-scale eight-integrator machine, presumably for more demanding research applications.

In January 1951, *Meccano Magazine* reported on a Meccano differential analyzer built in the University of Malaya, Singapore, by Prof. J.C. Cooke. The machine pictured there has only two integrators and an output table, but it bears a striking resemblance in its layout and construction to the Cambridge model, with non-Meccano two-stage torque amplifiers. The magazine article ends with "Prof. Cooke's model is not just a toy, or even a demonstration model. It is a mathematical calculating machine capable of serious work." Clearly, this sentence is an overstatement for a machine of only two integrators. However, the high standard of construction apparent from the picture, as well as the trouble taken to specially engineer two-stage amplifiers, may very well indicate that it was planned to extend the machine to four or five integrators, which would undoubtedly have rendered it a serious research tool. Cooke appears never to have published anything else in connection with this machine, and its further development and eventual fate remain unknown.

Many other demonstration models were constructed in colleges and universities. Few details were recorded about these models, and the very nature of Meccano means that almost all of them would have quickly been dismantled

and the parts reused for other purposes. Hartree mentions one [5] constructed by R. Stone and a group of VI form (high school senior year) boys at Macclesfield Grammar School, but provides no details.

Recently, however, in the United Kingdom, a two-integrator model machine in this class came to light in the estate of Mr. N. Eyres. Eyres had worked with Hartree during the war, and later was a teacher at Radley College, where he built the model. Figure 10 shows a picture of the machine as it was rediscovered, configured to solve the simple second-order equation for viscously damped harmonic motion, and still with output plotted on the output table. Only the original electric drive motor appears to have been removed. The date this machine was built is uncertain, since it appears to include Meccano parts that span a very wide time period from the 1930s to perhaps as late as 1964.

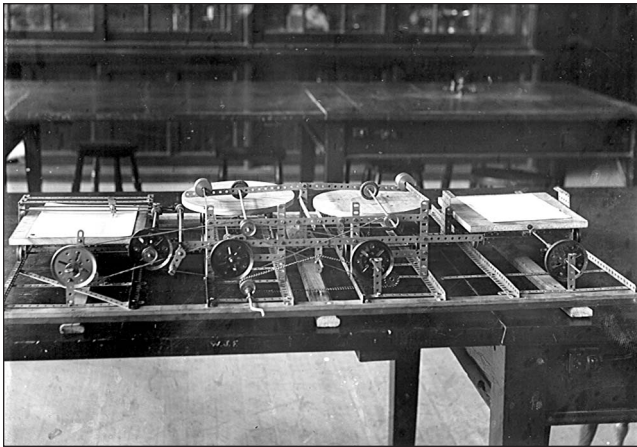

Figure 11. A delightfully simple model. This model, built by 15-year-old “Digby” Worthy around 1939, is remarkable for its simplicity. A system of belts and pulleys replaces the conventional geared interconnect, allowing the system to be constructed with a mere handful of parts. (Courtesy of P. Worthy.)

As was typical of these simple demonstration models, there are no torque amplifiers in Eyres’ model, these being difficult to construct using only Meccano parts. While the lack of torque amplifiers seriously limits accuracy, the output found along with Eyres’ model indicates that it was quite capable of solving a simple second-order equation with at least qualitatively correct results. It would have been more than adequate for its intended purpose as a calculus teaching aid.

Another example, remarkable for its simplicity, is a small two-integrator model built sometime between 1937–1939 by William “Digby” Worthy, who was only about 15 years old at the time and a student at Pocklington School in the north of England. As can be seen from Figure 11, Mr. Worthy was rather creative in replacing the

conventional geared interconnect with a system of belts and pulleys. While this simplification, plus the lack of torque amplifiers, means that only qualitative results would have been possible, it did allow Worthy to build a demonstration model from a mere handful of parts. In the photo, there is an output table to the left, and on the right an unfinished input table, presumably waiting for the acquisition of more parts; this was a constant problem for young Meccano enthusiasts at the time!

Epilogue

It is interesting that while in the 1930s and 1940s so many Meccano differential analyzer models were constructed, it was not until 1967 that a formal set of detailed model-building instructions was published [23]. Starting in the late 1960s, there was a resurgence of interest in advanced model-building in Meccano, mostly by retirees returning to a childhood passion now that they had time and resources; the differential analyzer remains a fascinating and challenging subject. The general standard of sophistication in the models produced by this generation of enthusiasts is way beyond anything created in Meccano’s heyday. A number of these enthusiasts, including the current author, have built demonstration differential analyzers [24], which include fully functioning torque amplifiers made entirely from Meccano parts, delivering performance comparable to the original prototype (see [24]).

While the full-scale machines and most of the early Meccano models have long since been either scrapped or consigned to museums in the form of static exhibits, it remains the case that students and members of the public who have the opportunity to observe a differential analyzer in operation find it captivating. By giving reality to the mathematical symbolism, the differential analyzer brings problems to life in a way that digital and electronic analog computers cannot. As solutions grow before their eyes, students who may have been finding calculus unfathomable often achieve enlightenment. It is to be hoped that the restoration of the Cambridge model to an operational state and the ongoing efforts of a few dedicated enthusiasts will, at least in a small way, allow another generation to enjoy this experience.

Acknowledgments

I am grateful to Dr. Garry Tee of the Mathematics Department, University of Auckland, New Zealand, for providing notes on the history of the Cambridge model in New Zealand, and to the permission granted to reproduce the images in Figures 1, 5, and 7–11.

References

- [1] V. Bush, “The differential analyzer. A new machine for solving differential equations,” *J. Franklin Inst.*, vol. 212, no. 1270, pp. 447–488, 1931.

[2] W. Thomson, "Mechanical integration of linear differential equations of the second order with variable coefficients," *Proc. Royal Soc.*, vol. 24, no. 167, pp. 269–270, 1876.

[3] V. Bush, *Pieces of the Action*. New York: William Morrow, 1970.

[4] C.W. Nieman, "Bethlehem torque amplifier," *Amer. Mach.*, vol. 66, no. 21, pp. 895–897, 1927.

[5] D.R. Hartree, "The mechanical integration of differential equations," *Math. Gazette*, vol. 22, no. 251, pp. 342–364, 1938.

[6] D.R. Hartree and A. Porter, "The construction and operation of a model differential analyser," *Mem. Proc. Manchester Liter. Philosoph. Soc.*, vol. 79, pp. 51–74, 1934–1935.

[7] A. Porter, "An approximate determination of the atomic wave functions of the chromium atom," *Mem. Proc. Manchester Liter. Philosoph. Soc.*, vol. 79, pp. 75–81, 1934–1935.

[8] A. Callendar, D.R. Hartree, and A. Porter, "Time lag in a control system," *Philosoph. Trans. Royal Soc. A*, vol. 235, no. 756, pp. 415–444, 1936.

[9] J.E. Lennard-Jones, M.V. Wilkes, and J.B. Bratt. "The design of a small differential analyser," *Proc. Cambridge Philosoph. Soc.*, vol. 35, pt. 3, pp. 485–493, 1939.

[10] M.V. Wilkes, *Memoirs of a Computer Pioneer*. Cambridge, MA: MIT Press, 1985.

[11] W.J. Cairns, J. Crank, and E.C. Lloyd, "Some improvements in the construction of a small scale differential analyser and a review of recent applications," *Armament Res. Dept., Theoretical Res. Memo.* 27/44, 1944.

[12] G.J. Tee, "Meccano differential analyser no. 2," unpublished.

[13] T. Macauley, "Operating the Meccano differential analyser," unpublished.

[14] I. Lowe, "Ancient computer down and out," *New Sci.*, vol. 138, no. 1873, p. 50, 15 Mar. 1993.

[15] D.R. Hartree, "Differential analyser," Ministry of Supply Permanent Records of Research and Development, 17–502, 1946–1949.

[16] A.M. Wood, "The design and construction of a small scale differential analyser and its application to the solution of a differential equation," M.Sc. thesis, Univ. Birmingham, 1942.

[17] H.S.W. Massey, J. Wylie, R.A. Buckingham, and R. Sullivan, "A small scale differential analyser—Its construction

and operation," *Proc. Royal Irish Acad.*, vol. 45A, no. 1, pp. 1–21, 1938.

[18] R.E. Beard, "The construction of a small scale differential analyser and its application to the calculation of actuarial functions," *J. Inst. Actuaries*, vol. 71, no. 2, pp. 193–227, 1942.

[19] B.H. Worsley, "Construction of a model differential analyzer," Worsley Archives, box 3, folder 10, Queen's University Archives, Ontario, 1948.

[20] B.H. Worsley, "Differential analyzer," Worsley Archives, box 3, folder 10, Queen's University Archives, Ontario.

[21] C.C. Gotlieb, private communication, Mar. 2004.

[22] A. Porter, private communication, June 2004.

[23] Anon, "Differential analyser," in *The GMM Series of Modern Supermodels no. 4*. London: The Meccanoman's Club, 1967.

[24] T. Robinson, "A reconstruction of the differential analyzer in Meccano," *IEEE Contr. Syst. Mag.*, vol. 25, no. 3, pp. 84–89, June 2005.

Tim Robinson (tbr00@pacbell.net) retired in 2003 from Broadcom Corporation, where, as senior director of engineering, he was responsible for the development of Broadcom's range of WiFi (802.11a/b/g) wireless networking chipsets. He holds bachelor's and master's degrees in physics from Oxford University. He entered the computing field in 1980 in the United Kingdom, where, as cofounder of High Level Hardware Ltd., he designed a user-microprogrammable computer system for developing novel programming languages. In 1989, he moved to the San Francisco Bay Area, where he has held senior engineering positions at a number of Silicon Valley startup companies. He maintains a strong interest in the early history of computing, particularly mechanical computing devices, and is actively involved in the restoration of these early machines and in the construction of working replicas of Charles Babbage's conceptual designs. Other interests include music, Meccano, and current developments in physics and cosmology. Tim can be contacted at 216 Blackstone Dr., Boulder Creek, CA 95006 USA. 

Natural Complexity

The central nervous system itself seems digital to digital men, and analog to analog men. If it is both, then it is more intimately and profoundly intermingled hybrid than any of the artificial structures which have come to light. One thing is pretty sure, and that is that the brain builds models. We are in good company.

—George A. Philbrick, "Analogues yesterday, today, and tomorrow, or metaphors of the continuum," in *Analog Circuit Design*, Jim Williams, Editor, Butterworth-Heinemann, 1991, p. 12.